

**Self-Priming Solids Handling Pumps**

**Specifications:**

**SUCTION/DISCHARGE** .....4" (102mm) x 4" (102mm) 125 lb. Flange

**LIQUID TEMPERATURE** .....160°F (71°C) Continuous

**SOLIDS HANDLING:**

PO4LA .....2" (51mm) Spherical

PO4LB .....3" (76mm) Spherical

**VOLUTE/WEARPLATE** .....Cast Iron ASTM A-48, Class 30  
Replaceable External Clearance  
Adjustment

**CASE**.....Cast Iron ASTM A-48, Class 30

**END COVER** .....Cast Iron ASTM A-48, Class 30  
Full Diameter, Removable

**SEAL PLATE** .....Alloy Steel, Replaceable

**PEDESTAL**.....Cast Iron ASTM A-48, Class 30

**IMPELLER: Design** .....Two Vane, Open. Dynamically Balanced,  
ISO G6.3

*Material* .....Ductile Iron ASTM A-395

**SHAFT** .....High Carbon Steel

**SHAFT SLEEVE** .....316 Stainless Steel

**SQUARE RINGS** .....Buna-N

**HARDWARE** .....Corrosion Resistant Steel

**PAINT** .....Air Dry Enamel.

**SEAL: Design** .....Single Mechanical

*Lubrication* .....Grease, with Self-Feeding Lubricator

*Material* .....Rotating Faces - Carbon  
Stationary Faces - Ceramic  
Elastomer - Buna-N  
Hardware -300 Series Stainless

**BEARING - PUMP END:**

*Design* .....Single Row, Ball, Oil Lubricated

*Load* .....Radial & Thrust

**BEARING - DRIVE END:**

*Design* .....Single Row, Ball, Oil Lubricated

*Load*.....Radial & Thrust

**CHECK VALVE:**

*Material* .....Elbow - Cast Iron ASTM A-48, Class 30  
Valve Flap - Neoprene  
Weight - Cast Iron ASTM A-48, Class 30

**OPTIONAL EQUIPMENT**.....Seal Materials, Case Heater, Stainless Hardware; Double Mechanical Seal, Oil Lubricated w/Pressure Compensating Lubricator; High Temperature Control; Flex Coupled Assy. with Base & OSHA Guard; Right Hand V-Belt Drive Assy. and Left Hand V-Belt Drive Assy., In-Line Vertical V-Belt Drive Assy., and Over Top V-Belt Drive Assy. with Unit Base, Motor Adjusting Base & OSHA Guard

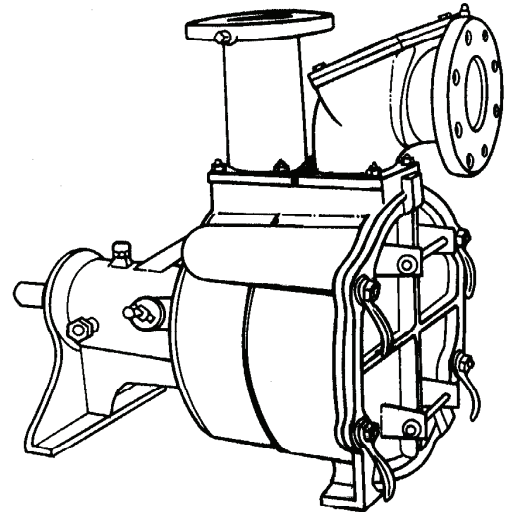

**Model: PO4LA-9D  
PO4LA-8D  
PO4LB-8D**

Sample Specifications: Section 4 Page 7-8.

**DESCRIPTION:**

SELF-PRIMING CENTRIFUGAL SOLIDS HANDLING PUMPS DESIGNED FOR MUNICIPAL AND INDUSTRIAL APPLICATIONS.

# Model: PO4LA, PO4LB

2" & 3" Spherical Solids Handling  
Universal Drive



## Self-Priming Solids Handling Pumps

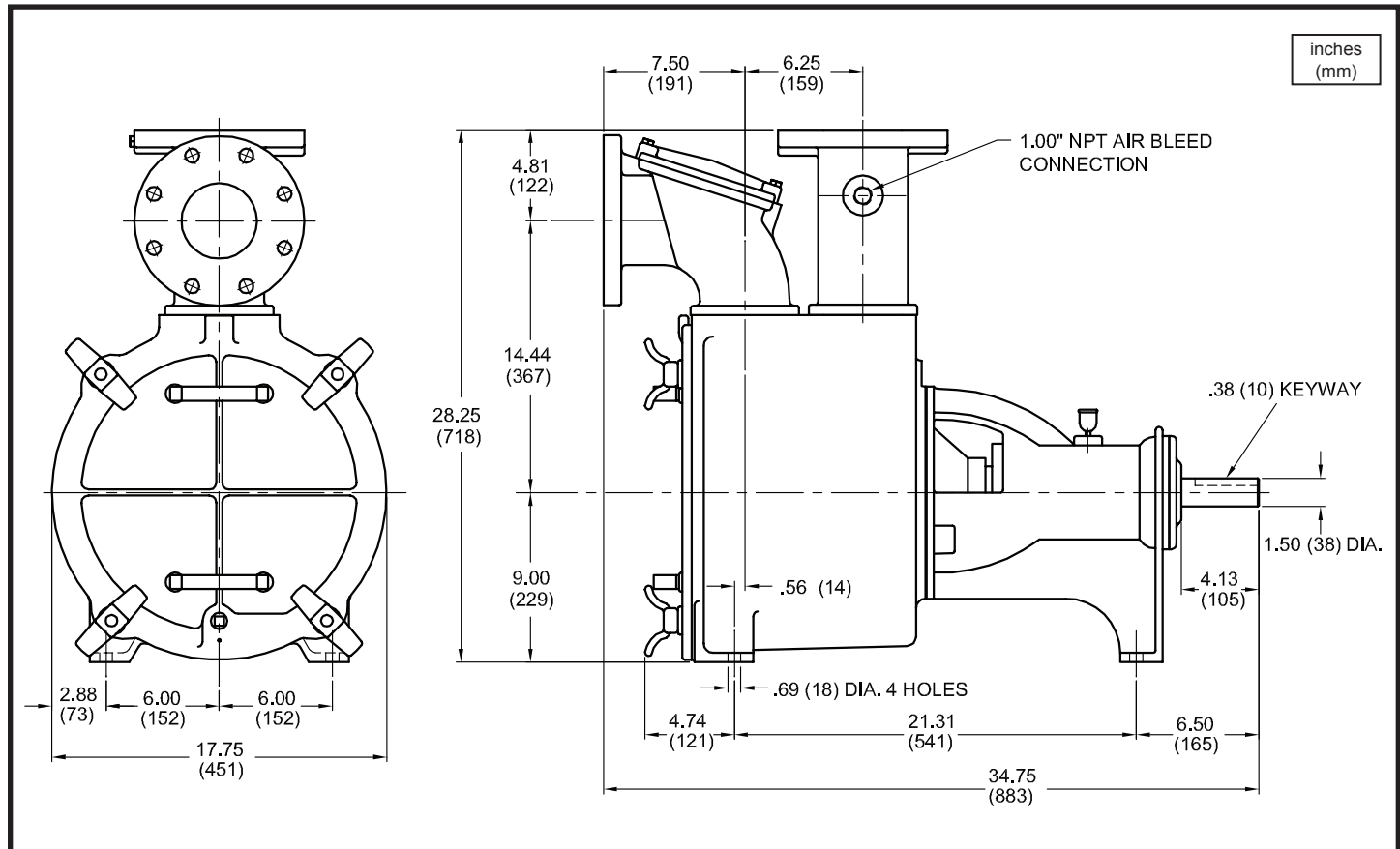

MODEL NO	PART NO	WEIGHT LBS. (kg)	
PO4LA-9D	4C02D-0009D-031	425 (193)	
PO4LA-8D	4C02D-0008D-031	425 (193)	
PO4LB-8D	4C04D-0008D-031	440 (200)	

**IMPORTANT !**

- DO NOT USE FOR PUMPING FLUIDS WITH A FLASH POINT OF LESS THAN 100°F.
- MAKE CERTAIN THAT PUMP AND/OR MOTOR ASSEMBLY AND CONTROLS HAVE THE APPROPRIATE RATINGS FOR THE GIVEN APPLICATION AREA CLASSIFICATION. (ie DIVISION I, AGENCY LISTING ETC.)

SECTION 4A  
PAGE 16  
DATE 4/05



A Crane Co. Company

## PUMPS & SYSTEMS

USA: (937) 778-8947 • Canada: (905) 457-6223 • International: (937) 615-3598

## Self-Priming Solids Handling Pumps

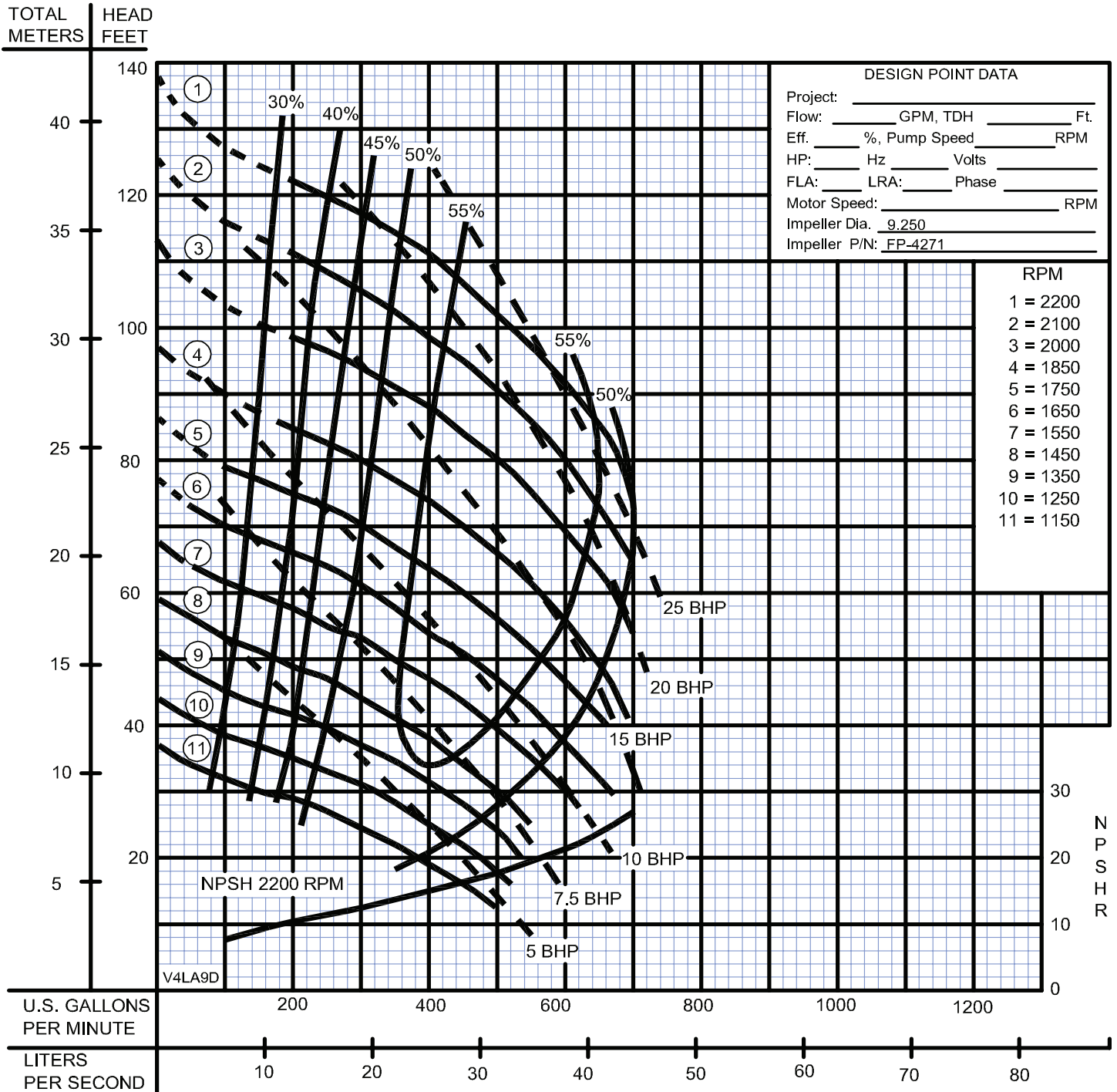

DESIGN POINT DATA	
Project:	_____
Flow:	_____ GPM, TDH _____ Ft.
Eff.:	_____ %, Pump Speed _____ RPM
HP:	_____ Hz _____ Volts _____
FLA:	_____ LRA: _____ Phase _____
Motor Speed:	_____ RPM
Impeller Dia.:	9.250
Impeller P/N:	FP-4271

RPM
1 = 2200
2 = 2100
3 = 2000
4 = 1850
5 = 1750
6 = 1650
7 = 1550
8 = 1450
9 = 1350
10 = 1250
11 = 1150

MAXIMUM DRY PRIMING LIFT					
PUMP SPEED	2 Min	4 Min	6 Min	8 Min	10 Min
1150 RPM	7 Ft.	12 Ft.	16 Ft.	19 Ft.	20 Ft.
1450 RPM	9 Ft.	15 Ft.	19 Ft.	21 Ft.	22 Ft.
1750 RPM	17 Ft.	25 Ft.	25 Ft.	25 Ft.	25 Ft.
2000 RPM	25 Ft.	25 Ft.	25 Ft.	25 Ft.	25 Ft.
2200 RPM	23 Ft.	25 Ft.	25 Ft.	25 Ft.	25 Ft.

When pump is operating, the **SUCTION LIFT** is limited by the available **NPSH** which is the corrected atmospheric pressure minus the dynamic suction lift, vapor pressure loss and 2 foot safety factor. This **net available NPSH** must exceed the **required NPSH** of the pump or a reduction of capacity, loss of efficiency, noise, vibration and cavitation will result. Calculate the dynamic suction lift from the **low** liquid level to the centerline of the impeller. When pump is priming, it is limited by the dry **PRIMING LIFT** which is the vertical distance from the **high** liquid level to the centerline of the impeller.

DO NOT Operate in "DASHED" Area of HQ Curve. Testing is performed with water, specific gravity 1.0 @ 68° F @ (20°C), other fluids may vary performance

# Model: PO4LA-8D

Performance Curve  
Various RPM



## Self-Priming Solids Handling Pumps

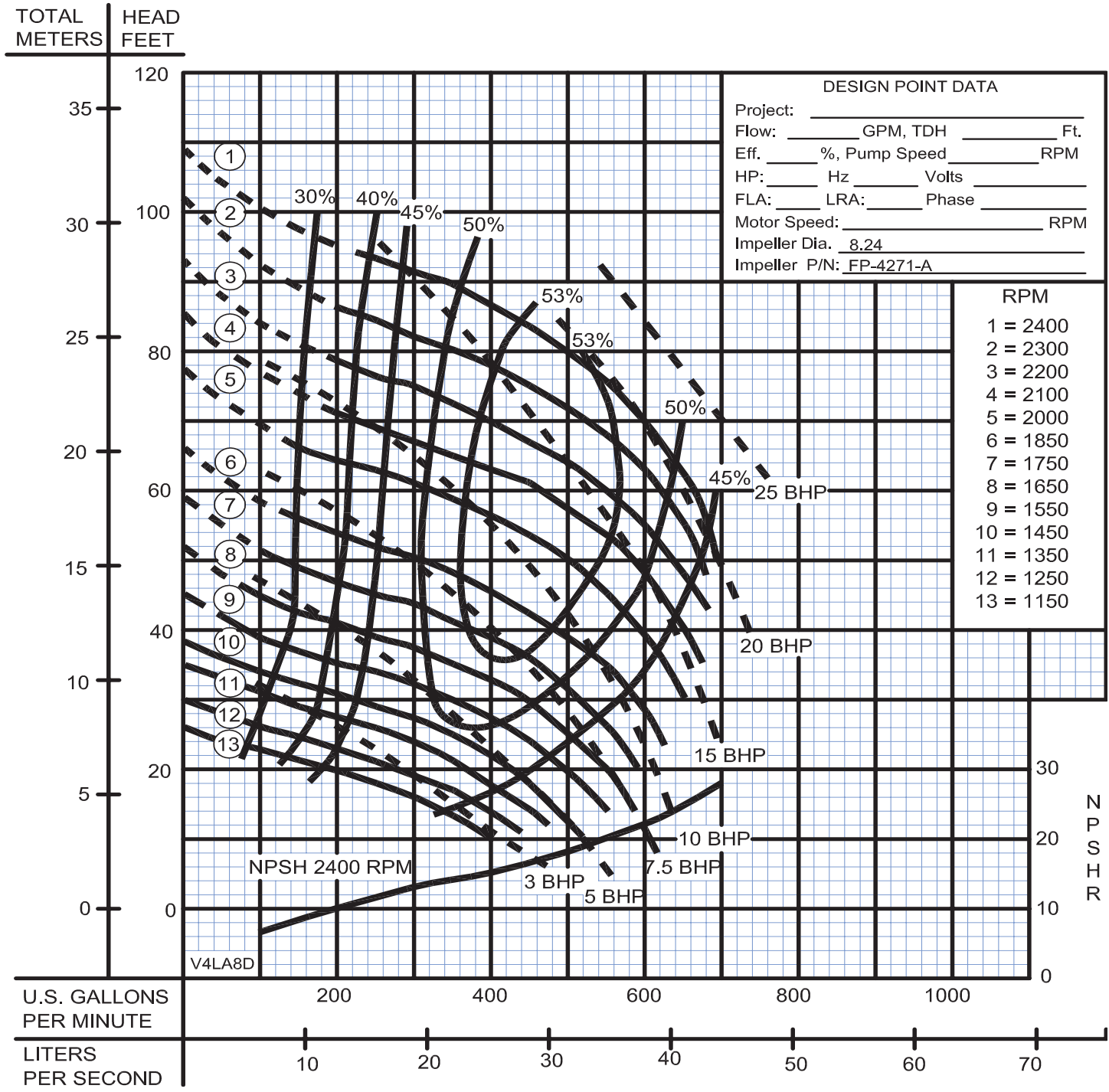

MAXIMUM DRY PRIMING LIFT					
PUMP SPEED	2 Min	4 Min	6 Min	8 Min	10 Min
1150 RPM	6 Ft.	11 Ft.	15 Ft.	18 Ft.	20 Ft.
1450 RPM	8 Ft.	15 Ft.	21 Ft.	24 Ft.	25 Ft.
1750 RPM	13 Ft.	21 Ft.	25 Ft.	25 Ft.	25 Ft.
2000 RPM	20 Ft.	25 Ft.	25 Ft.	25 Ft.	25 Ft.
2200 RPM	25 Ft.	25 Ft.	25 Ft.	25 Ft.	25 Ft.

When pump is operating, the **SUCTION LIFT** is limited by the available **NPSH** which is the corrected atmospheric pressure minus the dynamic suction lift, vapor pressure loss and 2 foot safety factor. This **net available NPSH** must exceed the **required NPSH** of the pump or a reduction of capacity, loss of efficiency, noise, vibration and cavitation will result. Calculate the dynamic suction lift from the **low** liquid level to the centerline of the impeller. When pump is priming, it is limited by the **dry PRIMING LIFT** which is the vertical distance from the **high** liquid level to the centerline of the impeller.

DO NOT Operate in "DASHED" Area of HQ Curve. Testing is performed with water, specific gravity 1.0 @ 68° F @ (20°C), other fluids may vary performance

SECTION 4A  
PAGE 18  
DATE 5/13



## PUMPS & SYSTEMS

A Crane Co. Company

USA: (937) 778-8947 • Canada: (905) 457-6223 • International: (937) 615-3598

## Self-Priming Solids Handling Pumps

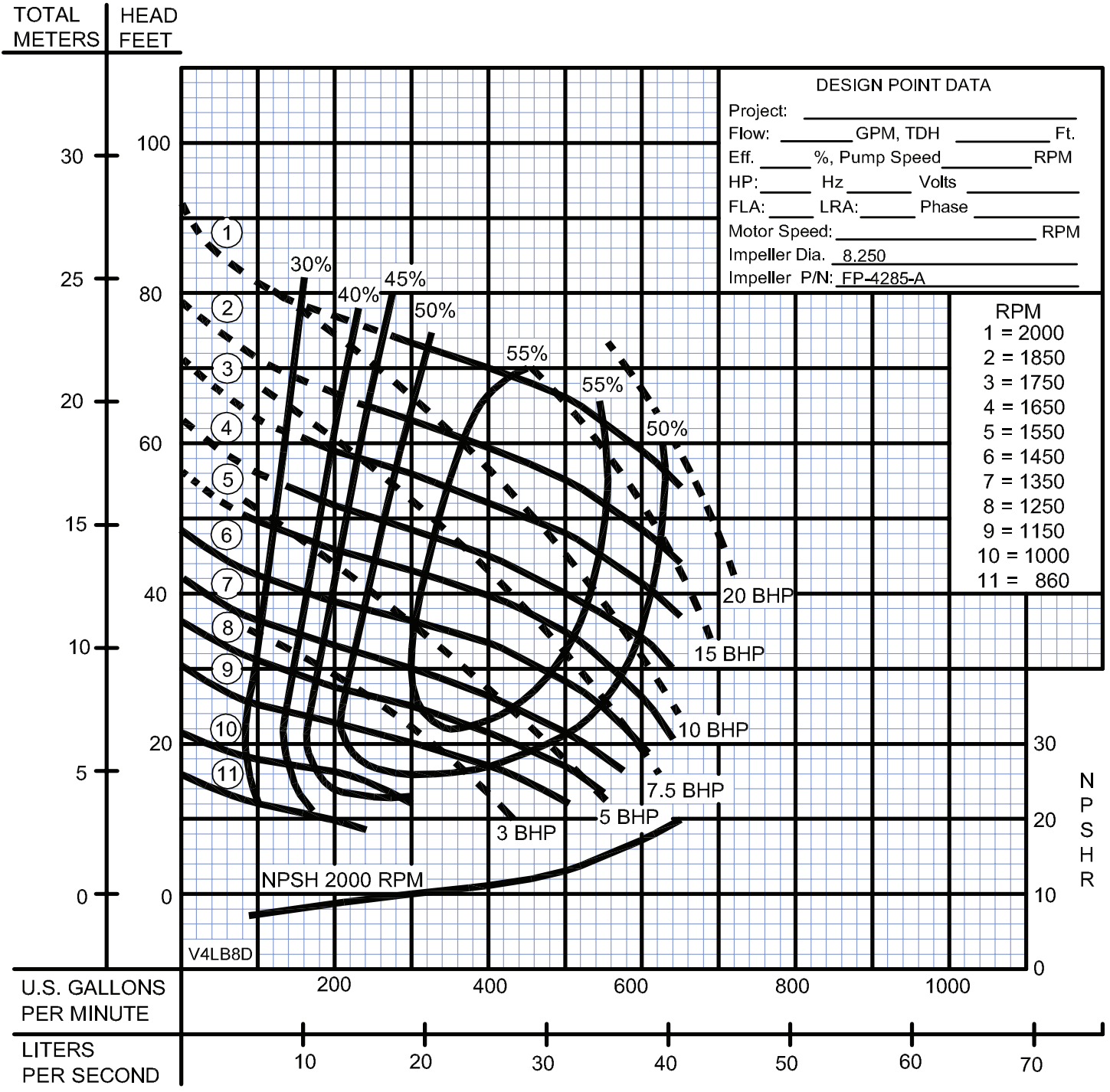

MAXIMUM DRY PRIMING LIFT					
PUMP SPEED	2 Min	4 Min	6 Min	8 Min	10 Min
860 RPM	5 Ft.	7 Ft.	9 Ft.	10 Ft.	11 Ft.
1150 RPM	7 Ft.	10 Ft.	13 Ft.	15 Ft.	17 Ft.
1450 RPM	9 Ft.	15 Ft.	18 Ft.	21 Ft.	24 Ft.
1750 RPM	12 Ft.	18 Ft.	21 Ft.	24 Ft.	25 Ft.
2000 RPM	18 Ft.	25 Ft.	25 Ft.	25 Ft.	25 Ft.

When pump is operating, the **SUCTION LIFT** is limited by the available **NPSH** which is the corrected atmospheric pressure minus the dynamic suction lift, vapor pressure loss and 2 foot safety factor. This **net available NPSH** must exceed the **required NPSH** of the pump or a reduction of capacity, loss of efficiency, noise, vibration and cavitation will result. Calculate the dynamic suction lift from the **low** liquid level to the centerline of the impeller. When pump is priming, it is limited by the dry **PRIMING LIFT** which is the vertical distance from the **high** liquid level to the centerline of the impeller.

DO NOT Operate in "DASHED" Area of HQ Curve. Testing is performed with water, specific gravity 1.0 @ 68° F @ (20°C), other fluids may vary performance

# Model: PO4LA, PO4LB

Horizontal V-Belt Base, Motor Speed: 1750 RPM  
 V-Belt Drive, Sheaves & Bushings, Pump Shaft: 1.50 Dia.



## Self-Priming Solids Handling Pumps

Driven Speed	Speed Ratio	Motor HP	Frame Size	Center Distance	Drive P/N		Driven Speed	Speed Ratio	Motor HP	Frame Size	Center Distance	Drive P/N
2400	1.37	40	324T	18.6	090876		1650	1.06	15	254T	18.4	090921
2400	1.37	30	286T	18.6	090877		1650	1.06	10	215T	18.4	090922
2400	1.37	25	284T	18.6	090877		1650	1.06	7.5	213-215T	18.4	090923
2400	1.37	20	256T	17.6	090878							
							1600	1.09	15	254T	18.2	090924
2350	1.34	30	286T	17.0	090879		1600	1.09	10	215T	18.2	090925
2350	1.34	25	284T	17.0	090880		1600	1.09	7.5	213-215T	18.2	090926
2350	1.34	20	256T	17.0	090881		1600	1.09	5	213T	18.2	090927
2350	1.34	15	254T	17.0	090882		1600	1.09	5	184T	18.2	090928
2300	1.31	30	286T	18.6	090883		1550	1.13	15	254T	17.6	090932
2300	1.31	25	284T	18.4	090884		1550	1.13	10	215T	17.6	090929
2300	1.31	20	256T	18.4	090885		1550	1.13	7.5	213-215T	17.6	090930
2300	1.31	15	254T	18.4	090886		1550	1.13	5	213T	17.6	090930
							1550	1.13	5	184T	17.6	090931
2250	1.29	25	284T	17.5	090887							
2250	1.29	20	256T	17.5	090888		1500	1.16	10	215T	18.5	090933
2250	1.29	15	245T	17.5	090889		1500	1.16	7.5	213-215T	18.5	090934
							1500	1.16	5	213T	18.5	090934
							1500	1.16	5	184T	18.5	090935
2200	1.25	25	284T	18.8	090890							
2200	1.25	20	256T	18.1	090891							
2200	1.25	15	254T	18.1	090892		1450	1.20	10	215T	17.9	090936
							1450	1.20	7.5	213-215T	17.9	090937
2150	1.23	25	284T	18.7	090893		1450	1.20	5	213T	17.9	090937
2150	1.23	20	256T	18.7	090894		1450	1.20	5	184T	17.9	090938
2150	1.23	15	254T	18.7	090895							
2100	1.20	25	284T	17.7	090896		1400	1.25	7.5	213-215T	18.6	090939
2100	1.20	20	256T	17.9	090897		1400	1.25	5	213T	18.6	090940
2100	1.20	15	254T	17.9	090898		1400	1.25	5	184T	18.6	090941
2050	1.17	20	256T	18.4	090899		1350	1.30	7.5	213-215T	17.5	090942
2050	1.17	15	254T	18.4	090900		1350	1.30	5	213T	17.5	090942
2050	1.17	10	215T	18.4	090901		1350	1.30	5	184T	17.5	090943
2000	1.14	20	256T	17.9	090902		1300	1.35	7.5	213-215T	18.8	090944
2000	1.14	15	254T	17.9	090903		1300	1.35	5	213T	18.8	090945
2000	1.14	10	215T	17.9	090904		1300	1.35	5	184T	18.8	090946
							1300	1.35	3	182-184T	18.8	090947
1950	1.11	20	256T	18.2	090905		1250	1.40	7.5	213-215T	18.6	090948
1950	1.11	15	254T	18.2	090906		1250	1.40	5	213T	18.6	090949
1950	1.11	10	215T	18.2	090907		1250	1.40	5	184T	18.6	090950
							1250	1.40	3	182-184T	18.6	090951
1900	1.09	20	256T	18.2	090908							
1900	1.09	15	254T	18.2	090909		1200	1.46	5	213T	18.5	090952
1900	1.09	10	215T	18.2	090910		1200	1.46	5	184T	18.5	090953
							1200	1.46	3	182-184T	18.5	090954
1850	1.06	20	256T	18.4	090911							
1850	1.06	15	254T	18.4	090912		1150	1.52	5	213T	18.8	090955
1850	1.06	10	215T	18.4	090913		1150	1.52	5	184T	18.8	090956
							1150	1.52	3	182-184T	18.8	090957
1800	1.03	15	254T	18.8	090914							
1800	1.03	10	215T	18.8	090915		1100	1.59	5	213T	18.9	090958
1800	1.03	7.5	213-215T	18.8	090915		1100	1.59	5	184T	18.9	090959
							1100	1.59	3	182-184T	18.9	090960
1750	1.00	15	254T	18.7	090916							
1750	1.00	10	215T	18.7	090917		1050	1.66	3	182-184T	18.9	090961
1750	1.00	7.5	213-215T	18.7	090918							
							1000	1.75	3	182-184T	17.8	090962
1700	1.03	15	254T	18.8	090919							
1700	1.03	10	215T	18.8	090920							
1700	1.03	7.5	213-215T	18.8	090920							

SECTION 4A  
 PAGE 20  
 DATE 4/05



## PUMPS & SYSTEMS

A Crane Co. Company

USA: (937) 778-8947 • Canada: (905) 457-6223 • International: (937) 615-3598