

Liberty Pumps®

X-Series™

XLSG200-Series



V-Slice® Technology



Patent: See
www.libertypumps.com/patents

2 hp
1-1/4" Discharge

**Explosion-proof
Submersible
Grinder Pump
for Hazardous
Locations**

**Class 1, Division 1,
Groups C, D T4**

**Class 1, Zone 1,
Group IIA, IIB T4**

For sewage applications where hazardous location ratings are required. Applications include groups of homes, commercial buildings, schools, lakefront development, and systems requiring high pressure sewage pumping.

Features:

- Patented V-Slice® Cutter Technology provides unmatched shredding performance of wipes, disposable cleaning pads, rags and other difficult solids.
- 440 hardened stainless steel cutter and plate
- Stainless steel impeller
- Dual mechanical seals – silicon carbide with Viton® elastomers
- Seal Fail Sensor
- 1-1/2" threads provided at power cords for optional conduit connection

For use with ISS and ISD-Series (intrinsically safe) panels.
Consult factory for proper panel sizing

innovate. evolve.



XLSG200-Series

TECHNICAL SPECIFICATIONS



CONSTRUCTION:

Pump and Motor Housing: Heavy cast iron - Class 30

Impeller: Stainless Steel

Motor: Submersible type, oil-filled, hermetically sealed

Bearings: Ball bearings upper and lower

Shaft: 300 Series Stainless Steel

Thermal Protection: Single phase models use integrated thermal protection with automatic reset; 3 phase models require overload relays in the pump control panel

Capacitor: Single phase pumps require start and run capacitors as well as a start relay

Shaft Seal: Dual mechanical seals – silicon carbide with Viton® elastomers

Seal Fail Sensor: Integral moisture sensing probe (functionality requires indicator in panel – see ISS or ISD-series panels)

Maximum Fluid Temperature: 104° F (40° C) Continuous duty rated

PERFORMANCE CURVE 60 Hz. 3450 RPM

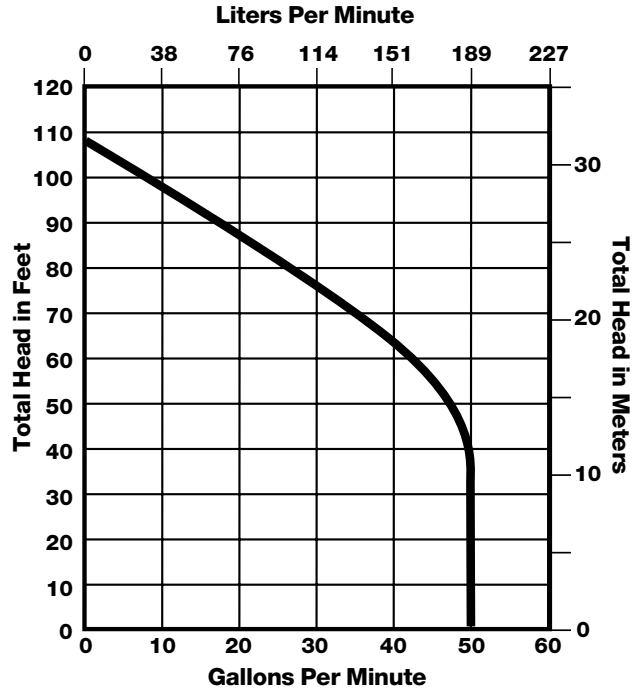

DIMENSIONAL DATA

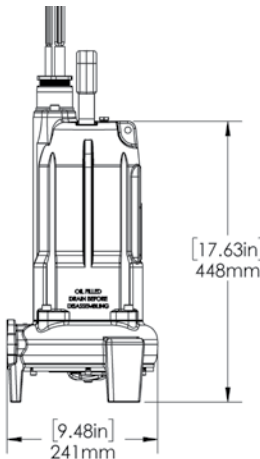
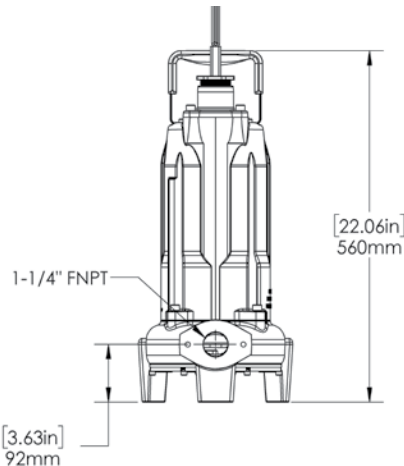
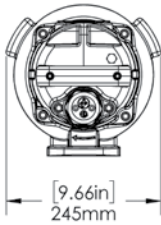

GR20NS non-sparking guide rail for hazardous location installations (sold separately).

XLSG200-Series

MODEL	HP	Volts	Ph	Hz	Amps	Locked Rotor Amps	Capacitor Kit	Discharge	Wgt
XLSG208M	2	200	1	60	18.1	66.5	K001640	1-1/4"	123
XLSG202M	2	230	1	60	15	64.3	K001641	1-1/4"	123
XLSG203M	2	200/230	3	60	12	39.2	N/A	1-1/4"	123
XLSG204M	2	460	3	60	6.2	19.6	N/A	1-1/4"	123
XLSG205M	2	575	3	60	5	16.3	N/A	1-1/4"	123

Power cord length is available in 25, 35 and 50 foot lengths. Cord length is designated by the suffix -2, -3, or -5 for the various lengths, e.g. XSLG203M-3 for 35' cord.

All X-Series grinders require the use of Liberty ISS or ISD control panels. Please contact the factory for assistance in panel selection.

Capacitor kit includes: Run cap, start cap, start relay.

Meets FM Standards



Specifications are subject to change without notice.