

MYERS® MWS9 Series

Cast Iron Submersible Sewage Pumps

MWS9 Series: 2" NPT Discharge

MWS39 Series: 3" NPT Discharge

SPECIFICATIONS

Applications	Sewage and Wastewater Removal and Transfer, Sump Drainage	
Capacities	235 GPM	889 LPM
Shut-off head	54'	16.5 m
Operation: Tethered:	Automatic Float Switch or Non-Automatic (manual) model available.	
Solids handling	2"	50.8 mm
Intermittent liquid temp	130°F	55°C
Min. Basin Diameter		
Simplex:	18"	457 mm
Duplex:	30"	762 mm
Motor	1, 1-1/2 and 2 HP, 1725 RPM, 230 Volt, single-phase, or 208-230/460 and 575 volt three-phase, 60 Hz. Oil-filled. PSC with thermal overload with built-in thermal overload protection with automatic reset and permanent split capacitor on single-phase only.	
Acceptable pH range	6-9	
Shaft seal	Primary: Mechanical type 21 or equal, Buna-N elastomers, silicon carbide seal faces, stainless steel metal parts; Secondary: self-lubricating energized nitrile lip seal	
Motor housing	Cast Iron	
Volute case	Cast Iron	
Impeller	Cast Iron Two-Vane Semi-Open Vortex	
Power cord	Single Phase: 20' UL/CSA Listed. 3 wire 16-3 SJTW-A/SJTW water resistant cord with integrally grounded three-prong plug. Three Phase: 20' UL/CSA Listed. 4 wire 16-4 SJTW-A/SJTW water resistant cord.	
Discharge	2" NPT vertical discharge: The MWS9	3" NPT vertical discharge: The MWS39



3 YEAR
WARRANTY



FEATURES

- Impeller – Non-clog vortex style, pump out vanes for seal protection.
- Dual Shaft Seals – Primary mechanical seal with a secondary self-lubricating lip seal.
- Bearing and Mechanical Seal – Permanently lubricated for long life.
- Serviceability – Heavy-duty lift-out ring, field serviceable.
- Overload Protection – Built-in thermal overload with automatic reset on single phase
- Cord Design – Prevents oil loss from and moisture protection for motor.
- Controls – Standard controls available for automatic operation.

ORDERING INFORMATION

Catalog Number	HP	Max. Load Amps	Volts	Phase/Cycles	Cord Length	Mechanical Switch Type	Discharge
MWS9100220M	1	8.5	230	1/60	20'	Manual	2" NPT
MWS9100220T						Tethered	
MWS9150220M	1-1/2	12.0	460	3/60		Manual	
MWS9150420M							
MWS9200220M	2	13.0	230	1/60		Manual	
MWS9200420M							
MWS39100220M	1	8.5	230	1/60		Tethered	3" NPT
MWS39100220T							
MWS39100520M	1-1/2	3.5	575	3/60		Manual	
MWS39150220M							
MWS39150520M	2	12.0	230	1/60	Manual		
MWS39150520M							
MWS39200220M	2	13.0	230	1/60	Manual		
MWS39200320M							
MWS39200520M							
MWS39200520M		4.2	575	3/60			

In order to provide the best products possible, specifications are subject to change.

MYERS® MWS9 Series

Cast Iron Submersible Sewage Pumps

MWS9 Series: 2" NPT Discharge

MWS39 Series: 3" NPT Discharge

OUTLINE DIMENSIONS

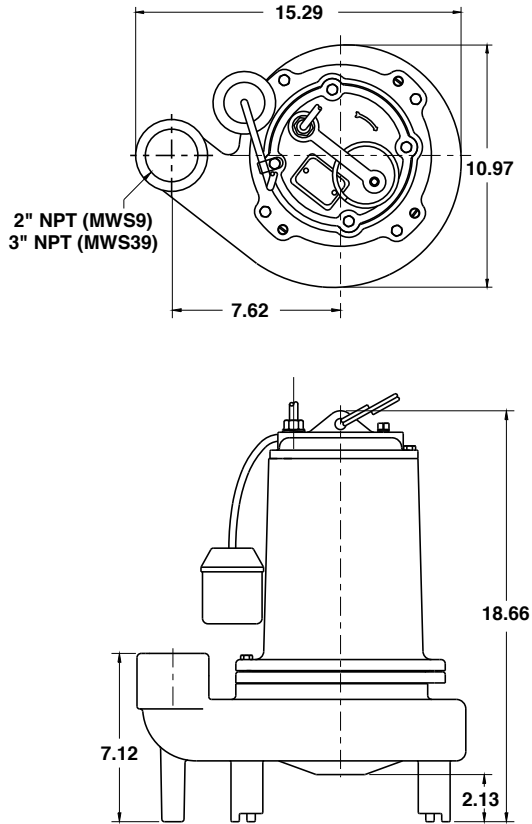

Dimensions (in inches) are for estimating purposes only.

PUMP PERFORMANCE

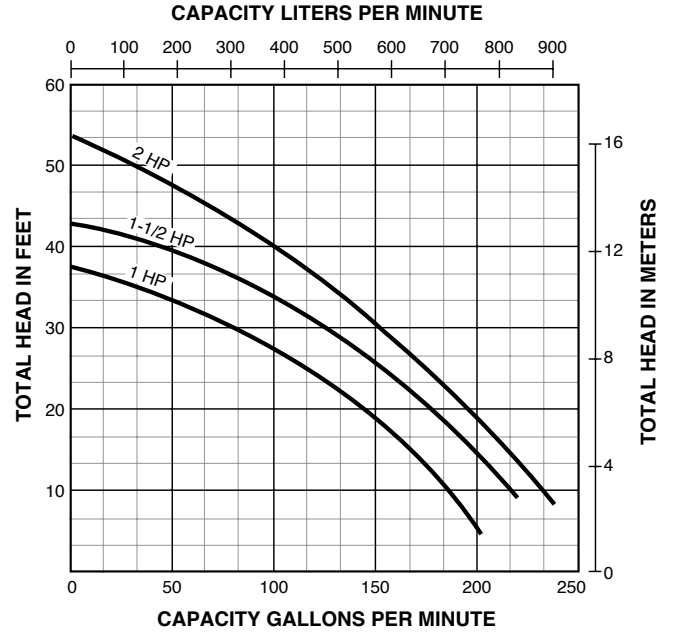

USA
293 WRIGHT STREET, DELAVAN, WI 53115 WWW.FEMYERS.COM
PH: 888-987-8677 ORDERS FAX: 800-426-9446

CANADA
490 PINEBUSH ROAD, UNIT 4, CAMBRIDGE, ONTARIO, N1T 0A5
PH: 800-363-7867 FAX: 888-606-5484

Because we are continuously improving our products and services, Pentair reserves the right to change specifications without prior notice.