

**FEATURES**

Impeller: Cast iron, ASTM A48, Class 30, two vane semi-open, non-clog design with pump out vanes for mechanical seal protection. Computer balanced for smooth operation. Silicon bronze impeller is an option.

Casing: Heavy duty gray cast iron, ASTM A48, Class 30. Volute type casing with 3", 125#, flanged, horizontal discharge conforming to ANSI standards. Compatible with A10-30 cast iron or A10-30B cast iron and brass (non-sparking) slide rail assembly.

Seals: Tandem mechanical seal system in an oil filled seal chamber. Each seal operates independently to ensure fail safe performance. Standard seals are carbon rotary and ceramic stationary. Outer seals are designed for easy replacement. Optional seals are available.

Seal Sensor Probes: Pump has a standard dual probe moisture detection system located in an oil filled seal chamber. The sensor leads must be connected to a "seal fail circuit" in the control panel.

3SDX

 EXPLOSION PROOF SUBMERSIBLE SEWAGE PUMP

CLASS 1, DIVISION 1, GROUPS C AND D HAZARDOUS LOCATIONS

APPLICATIONS

Designed for a variety of hazardous commercial and industrial applications such as:

- Sewage systems
- Flood and pollution control
- Dewatering and effluent
- Hospitals
- Trailer courts
- Hotels and motels

SPECIFICATIONS

Pump:

- Maximum solid size: 2.5"
- Discharge size: 3" ANSI 125# Flange
- Maximum capacity: 550 GPM
- Maximum total head: 67'

MOTOR SPECIFICATIONS

- Maximum ambient temperature: 40° C (104° F)
- Rated for continuous duty with motor fully submerged
- Service Factor: 1.15
- HP range: Three phase: 1.5 to 7.5 HP
- 60 Hz Voltages available:
Three phase: 200, 230, 460 and 575
- Insulation: Class F
- Single row ball bearings

MOTOR FEATURES

- Explosion Proof Motor: For use in hazardous locations. Rated Class 1, Division 1, Groups C & D.
- Standards: All motors conform to the latest requirements of NEMA, IEEE, ANSI and NEC standards.
- Air filled motor
- Class F insulation
- Thermal Protection System: The motor is equipped with two automatic reset on-winding thermostats to protect it from high temperatures.
- Operating Design: Motors are designed for continuous submerged operation. The maximum allowable run time in air is 15 minutes.
- Bearings: Single row greased for life sealed bearings. Rated for minimum L10 life of 17,500 hours. The bearings are designed to carry the radial and thrust loads.
- Cable Entry: Power and control cables are epoxy encapsulated to prevent wicking even if the cable jacket is punctured. Buna-N grommets provide an additional cable seal.
- Shaft: The shaft is 416 stainless steel.
- Power and Control Cables: Standard length is 25', optional 50' is available. The power leads are sized from 14/4 to 10/4 depending on HP and voltage, rated as SOW and SOOW. The control cable is 18/5 SOW cable.

AGENCY LISTINGS



Tested by CSA to UL Std's 778, 1207 and 674
 Tested by CSA to CSA 22.2 Std's 108-M89 and 145-M1986.
 These ratings cover use in Hazardous (Classified) Locations
 Class I, Division 1, Groups C & D; Class II, Groups E, F & G.
 File #LR38549

CONTROL PANEL REQUIREMENTS

To maintain warranty coverage and agency listings, Control Panels must have:

- Moisture Detection System - to warn of a seal failure.
- Thermal Protection System - winding thermostats open the pilot circuit of the magnetic motor controller before dangerous temperatures are reached.
- Overload (Over Current) Protection - Class 10, quick-trip type overload protection must be provided in control panel.
- Intrinsically Safe Relays - use "intrinsically safe relays" in a Class 1, Division 1, environment to power the float switches. They eliminate the danger of a spark if a switch cord becomes damaged. Intrinsically Safe Relays are available as an option from most panel suppliers. Other level control systems are available and may be applicable for this service, consult with your control manufacturer.

Typical Control Option:

- Guaranteed Pump Submergence Float - Many engineers specify a redundant OFF float or a Guaranteed Pump Submergence Circuit. This provides a second OFF float as protection from "OFF" float failure or hang up which protects the pump(s) from running dry.

PUMP ORDER NUMBERS AND GENERAL INFORMATION

Pump Order No.	HP	Imp. Dia.	Phase	Volts	RPM	1.15 SF Amps	Impeller Code	Full Load Amps	Locked Rotor Amps	Power Cord	Power Cable Diameter (in.)	18/5 Control Cable Dia. (in.)	Wt. (lbs.)
3SDX12F2KC	1½	5.81"	3	200	1750	5.9	K	5.3	42.0	14/4	0.58	0.495	250
3SDX12F3KC				230		5.1	K	4.6	36.6				
3SDX12F4KC				460		2.6	K	2.3	18.3				
3SDX12F5KC				575		2.0	K	1.8	14.6				
3SDX12G2JC	2	6.12"	3	200		7.6	J	6.8	50.6	14/4	0.58		
3SDX12G3JC				230		6.6	J	5.9	44.0				
3SDX12G4JC				460		3.3	J	2.9	22.0				
3SDX12G5JC				575		2.6	J	2.8	17.6				
3SDX12H2HC	3	6.75"	3	200		11.3	H	10.1	71.5	14/4	0.58		
3SDX12H3HC				230		9.8	H	8.8	62.1				
3SDX12H4HC				460		4.9	H	4.4	31.1				
3SDX12H5HC				575		3.9	H	3.5	24.9				
3SDX12J2GC	5	7.62"	3	200		18.3	G	17.0	92.1	12/4	0.66		
3SDX12J3GC				230		15.9	G	13.9	80.1				
3SDX12J4GC				460		8.0	G	7.0	40.0	14/4	0.58		
3SDX12J5GC				575		6.4	G	5.6	32.0				
3SDX12K2FC	7½	8.31"	3	200	26.7	F	23.3	144.0	10/4	0.73			
3SDX12K3FC				230	23.1	F	20.2	125.0					
3SDX12K4FC				460	11.6	F	10.1	62.5	14/4	0.58			
3SDX12K5FC				575	9.2	F	8.1	50.0					

NOMENCLATURE DESCRIPTION

1st - 4th Characters - Discharge Size and Type

3SDX = 3" discharge, 2½" solids handling, dual seal, Explosion Proof Sewage Pump

5th Character - Lower (outer) Mechanical Seal

The upper seal is carbon/rotary, ceramic/stationary, with Buna elastomers and 304SS metal parts - it is non-modifiable. The 5th character identifies which lower (outer) seal is to be ordered:

- 1 = Standard Lower Seal - Carbon/rotary, ceramic/stationary, Buna elastomers, 304SS metal parts
- 3 = Optional Lower Seal - Silicon carbide/rotary, silicon carbide/stationary, Viton, 304SS
- 5 = Optional Lower Seal - Silicon carbide/rotary, tungsten carbide/stationary, Viton, 304SS

6th Character - Cycle/RPM

2 = 60 Hz/1750 RPM 6 = 50 Hz/1450 RPM

7th Character - Horsepower

F = 1½ HP H = 3 HP K = 7½ HP
G = 2 HP J = 5 HP

8th Character - Phase/Voltage/Hertz

- 2 = three phase, 200 V, 60
- 3 = three phase, 230 V, 60
- 4 = three phase, 460 V, 60
- 5 = three phase, 575 V, 60
- 6 = three phase, 380 V, 50

9th Character - Impeller Diameter

- K = 5.81" - 1½ HP at 1.15 service factor
- J = 6.12" - 2 HP at 1.15 service factor
- H = 6.75" - 3 HP at 1.15 service factor
- G = 7.62" - 5 HP at 1.15 service factor
- F = 8.31" - 7½ HP at 1.15 service factor
- T = Special trim

10th Character - Cord Length (Power and Sensor)

C = 25' standard length F = 50' optional length

11th/12th Characters - Options

B = Bronze impeller E = Epoxy paint BE = Both

Example: Catalog Order Number 3SDX12F2KC = (3SDX) a 3" discharge, 2.5" solids pump with (1) standard seals, (2) 60 Hz/1750 rpm, (F) 1.5 hp, (2) 200 volt/three phase, (K) 5.81" impeller diameter, (C) standard 25' cord.

APPLICATION DATA

Maximum Solid Size	2½"
Minimum Casing Thickness	⅝"
Casing Corrosion Allowance	⅛"
Maximum Working Pressure	100 PSI
Maximum Submergence	200 feet depth
Maximum Environmental Temperature	40°C (104°F) ambient conditions
Maximum Starts Per Hour	10 evenly distributed starts/stops per hour

CONSTRUCTION DETAILS

Power Cable - Type	10/4, 12/4, 14/4 SOW, SOOW
Control / Sensor Cable / Type	18/5 SOW
Cable Cap Assembly	Leads have a Buna grommet and are encapsulated in epoxy for a positive seal
Power and Control Cable Lengths	25' standard, 50' optional
Motor Enclosure	Cast Iron, ASTM A-48, Class 30 (minimum)
Motor Shaft	416 Stainless Steel
Motor Design	NEMA Design B - Air-filled
Motor Insulation	Class "F", 155° C (310° F) insulation
Motor Thermal Protection	Two (2) normally closed on-winding thermostats open at 153° C (307° F), automatic reset closes at 140° C (284° F)
Motor Overload Protection	Require Class 10, quick-trip, ambient compensated overloads in the control panel
Motor Moisture Protection	Dual moisture sensing probes in an oil-filled seal chamber between inner and outer seals - Connect to a relay in control panel
Casing	Cast Iron, ASTM A-48, Class 30
Impeller	Cast Iron, ASTM A-48, Class 30 or Optional Cast Bronze ASTM B584 C87600
Impeller Type	Semi-open, non-clog with pump out vanes on back shroud, computer dynamically balanced

STANDARD PARTS

Ball Bearings	Greased for life, single row, upper and lower ball bearings, L10 rating life of 17,500 hours	
Mechanical Seals - Standard	Upper	Carbon - rotary / ceramic - stationary / Buna elastomers / 304SS metal parts
	Lower	
Mechanical Seals - Optional	Lower	Silicon carbide - rotary / silicon carbide - stationary / Viton / 304SS
	Lower	Silicon carbide - rotary / tungsten carbide - stationary / Viton / 304SS
Standard O-Rings	BUNA-N (nitrile)	
External Hardware	Stainless steel	

xylem
Let's Solve Water

Xylem Inc.
2881 East Bayard Street Ext., Suite A
Seneca Falls, NY 13148
Phone: (866) 325-4210
Fax: (888) 322-5877
www.gouldswatertechnology.com

Goulds is a registered trademark of Goulds Pumps, Inc. and is used under license.
© 2015 Xylem Inc. B3SDX R1 March 2015

DIMENSIONS

(All dimensions are in inches. Do not use for construction purposes.)

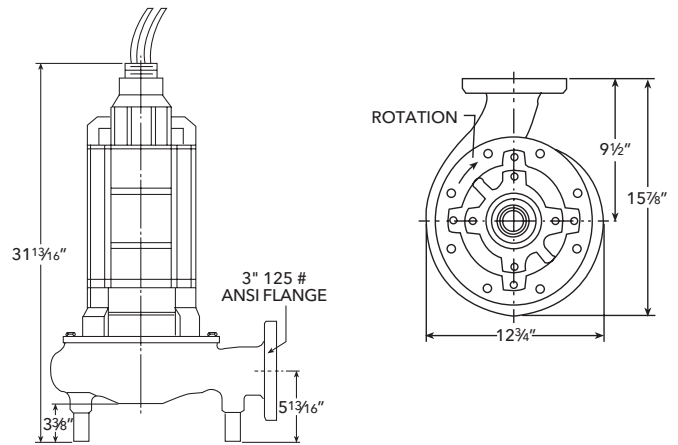

MATERIALS OF CONSTRUCTION

Item No.	Part Name	Material				
		Standard	Optional			
1	Impeller, non-clog	1003	1179			
2	Casing	1003				
3	Shaft-keyed	416 Series SS				
4	Fasteners	300 Series SS				
5	Impeller Bolt	Steel				
6	Motor Enclosure	Cast Iron	Additional lengths			
7	Power and Control Cables	25', SOW/SOOW				
8	Outer Mech. Seal	Service	Rotary	Stationary	Elastomers	Metal Parts
	OPT	Heavy duty	Silicon Carbide	Sil. Carb. Tung. Carb.	Viton	304 Series SS
	STD	Mild abrasives	Carbon	Ceramic	BUNA-N	304 Series SS
Material Code		Engineering Standard				
1003		Cast iron – ASTM A48 Class 30				
1179		Silicon bronze – ASTM B584 C87600				

