

CRN 125

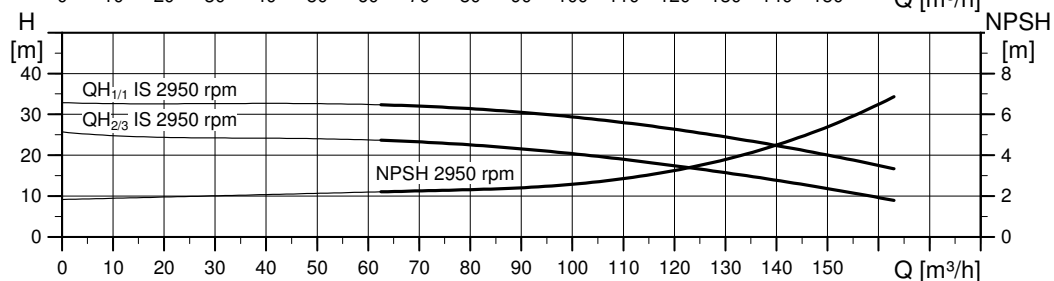
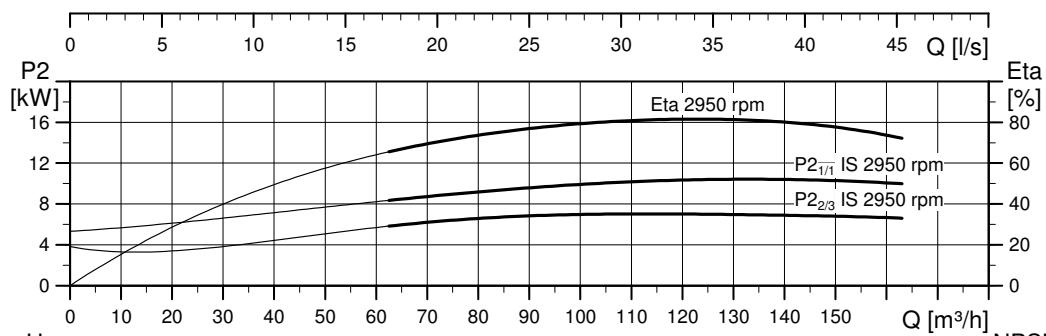
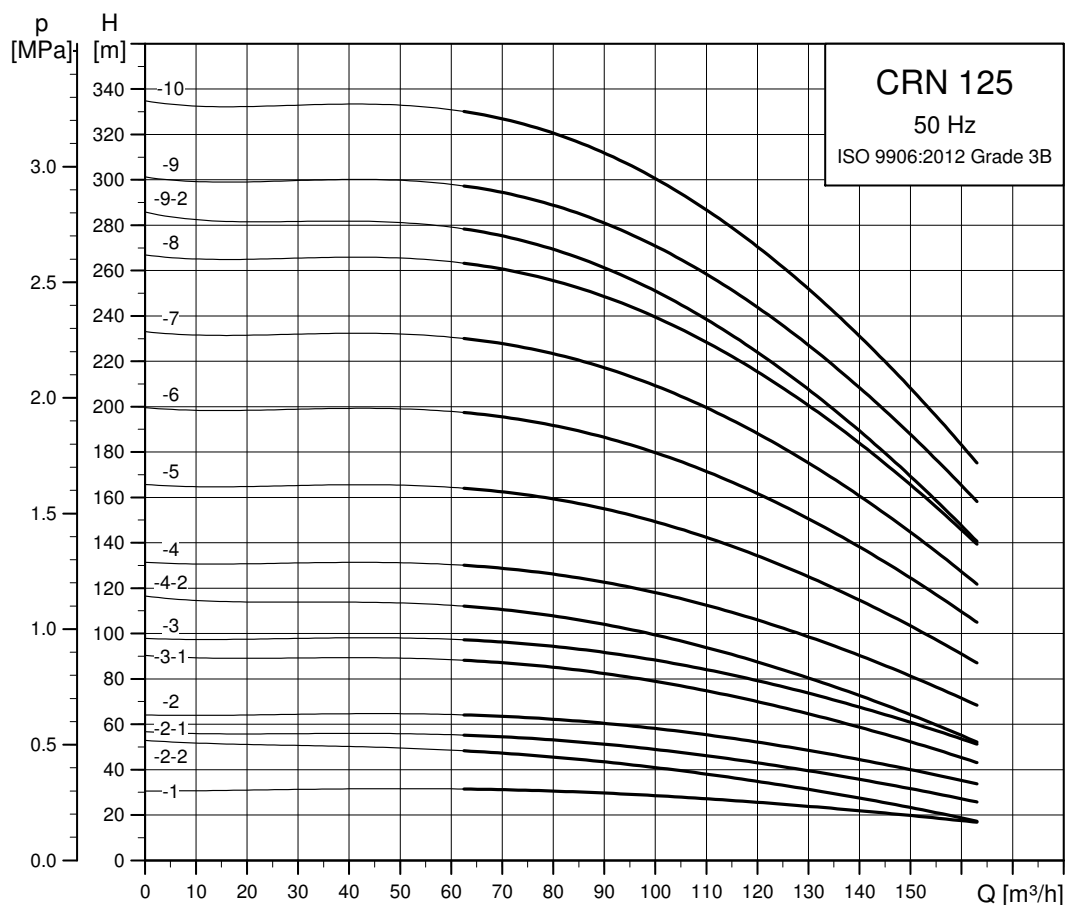

The maximum pump efficiency (ETA) is based on a three-stage pump.

TM06 5126 1318

Dimensional sketch

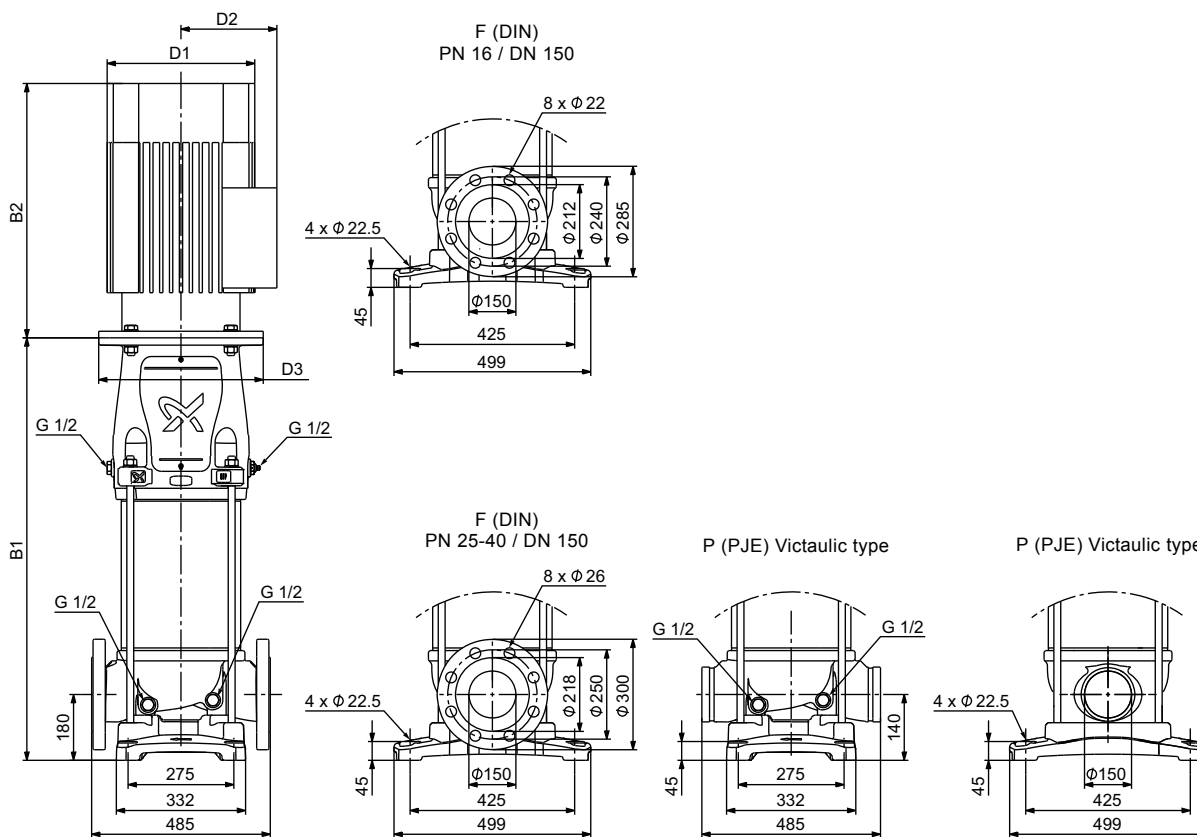

TM06 5095 4317

Dimensions and weights

Pump type	Motor P ₂ [kW]	CRN					Net weight [kg]
		B1	B1+B2	D1	D2	D3	
CRN 125-1	11	783	1254	314	204	350	213
CRN 125-2-2	15	905	1376	314	204	350	235
CRN 125-2-1	18.5	905	1420	314	204	350	248
CRN 125-2	22	905	1446	314	204	350	263
CRN 125-3-1	30	1029	1640	396	315	400	390
CRN 125-3	37	1029	1665	396	315	400	415
CRN 125-4-2	37	1151	1787	396	315	400	425
CRN 125-4	45	1174	1882	449	338	450	501
CRN 125-5	55	1294	2041	497	410	550	603
CRN 125-6	75	1416	2236	551	433	550	723
CRN 125-7	75	1538	2358	551	433	550	733
CRN 125-8	90	1660	2590	551	433	550	828
CRN 125-9-2	90	1782	2712	551	433	550	839
CRN 125-9	110	1812	2724	616	515	660	1025
CRN 125-10	110	1934	2846	616	515	660	1035